



Ultrasonic Transmitters

LU-150 (Sitrans LU-150)

Operating Instructions

Edition

06/2016

Ultrasonic transmitters SITRANS LU150

Operating Instructions

<u>Introduction</u>	1
<u>Description</u>	2
<u>Installing and mounting</u>	3
<u>Connecting</u>	4
<u>Commissioning</u>	5
<u>Operating</u>	6
<u>Troubleshooting</u>	7
<u>Technical data</u>	8
<u>Appendix</u>	A

Legal information

Warning notice system

This manual contains notices you have to observe in order to ensure your personal safety, as well as to prevent damage to property. The notices referring to your personal safety are highlighted in the manual by a safety alert symbol, notices referring only to property damage have no safety alert symbol. These notices shown below are graded according to the degree of danger.

DANGER

indicates that death or severe personal injury **will** result if proper precautions are not taken.

WARNING

indicates that death or severe personal injury **may** result if proper precautions are not taken.

CAUTION

indicates that minor personal injury can result if proper precautions are not taken.

NOTICE

indicates that property damage can result if proper precautions are not taken.

If more than one degree of danger is present, the warning notice representing the highest degree of danger will be used. A notice warning of injury to persons with a safety alert symbol may also include a warning relating to property damage.

Qualified Personnel

The product/system described in this documentation may be operated only by **personnel qualified** for the specific task in accordance with the relevant documentation, in particular its warning notices and safety instructions. Qualified personnel are those who, based on their training and experience, are capable of identifying risks and avoiding potential hazards when working with these products/systems.

Proper use of Siemens products

Note the following:

WARNING

Siemens products may only be used for the applications described in the catalog and in the relevant technical documentation. If products and components from other manufacturers are used, these must be recommended or approved by Siemens. Proper transport, storage, installation, assembly, commissioning, operation and maintenance are required to ensure that the products operate safely and without any problems. The permissible ambient conditions must be complied with. The information in the relevant documentation must be observed.

Trademarks

All names identified by ® are registered trademarks of Siemens AG. The remaining trademarks in this publication may be trademarks whose use by third parties for their own purposes could violate the rights of the owner.

Disclaimer of Liability

We have reviewed the contents of this publication to ensure consistency with the hardware and software described. Since variance cannot be precluded entirely, we cannot guarantee full consistency. However, the information in this publication is reviewed regularly and any necessary corrections are included in subsequent editions.

Table of contents

1	Introduction.....	5
2	Description.....	7
3	Installing and mounting.....	9
3.1	Environmental.....	9
3.2	Location.....	9
3.3	Threaded.....	10
3.4	Flange adapter (optional).....	12
3.5	4" Sanitary.....	13
3.6	LU150 with FMS200 mounting bracket.....	16
4	Connecting.....	17
4.1	Cable entry.....	17
4.2	System diagram.....	18
4.3	Wiring connection.....	19
5	Commissioning.....	21
5.1	Start up.....	21
5.2	Calibration.....	22
5.3	Calibration: reference method.....	22
5.4	4 mA calibration.....	23
5.5	20 mA calibration.....	23
5.6	Operation status.....	24
6	Operating.....	25
6.1	Adjustments.....	25
6.2	Calibration, scrolling method.....	26
6.3	4 mA calibration.....	26
6.4	20 mA calibration.....	27
6.5	Blanking.....	27
6.6	Adjusting the blanking value.....	28
6.7	Speed of response.....	29
6.8	Adjusting the speed of response.....	30
6.9	Fail-safe.....	30
6.10	Adjusting the fail-safe setting.....	31

6.11	Fail-safe timer	31
6.12	Adjusting the fail-safe timer.....	31
6.13	Units	32
6.14	Adjusting the units.....	32
7	Troubleshooting.....	33
7.1	Troubleshooting	33
8	Technical data	35
8.1	Power	35
8.2	Performance.....	35
8.3	Interface	35
8.4	Outputs.....	36
8.5	Construction	36
8.6	Operating conditions	36
8.7	Approvals	37
A	Appendix.....	39
A.1	Measurement interval	39

Introduction

Note**For industrial use only**

This product is intended for use in industrial areas. Operation of this equipment in a residential area may cause interference to several frequency based communications.

Note**Unit repair**

All changes and repairs must be done by qualified personnel, and applicable safety regulations must be followed. Please note the following:

- The user is responsible for all changes and repairs made to the device.
 - All new components must be provided by Siemens.
 - Restrict repair to faulty components only.
 - Do not re-use faulty components.
-

Description

The SITRANS LU150 is an ultrasonic level monitor combining sensor and electronics in a single package. It is designed to measure liquid levels in open or closed vessels. The process part (sensor) is PVDF, allowing the SITRANS LU150 to be used in a wide variety of industries, especially food and chemical.

The sensor houses the ultrasonic transducer and temperature sensing element. The SITRANS LU150 emits a series of ultrasonic pulses from the transducer. Each pulse is reflected as an echo from the material and sensed by the transducer. The echo is processed by the SITRANS LU150 using Siemens' proven 'Sonic Intelligence' techniques. Filtering is applied to help discriminate between the true echo from the material, and false echoes from acoustical and electrical noises and agitator blades in motion. The time for the pulse to travel to the material and back is temperature compensated and then converted into distance for the mA output.

Installing and mounting

3.1 Environmental

The SITRANS LU150 should be mounted in an area that is within the temperature range specified, and that is suitable to the housing rating and materials of construction.

It is advisable to keep the device away from high voltage or current runs, contactors and SCR control drives.

3.2 Location

Locate the SITRANS LU150 so that it will have a clear sound path that is perpendicular to the liquid surface.

The SITRANS LU150 sound path should not intersect the fill path, rough walls, seams, rungs, etc.

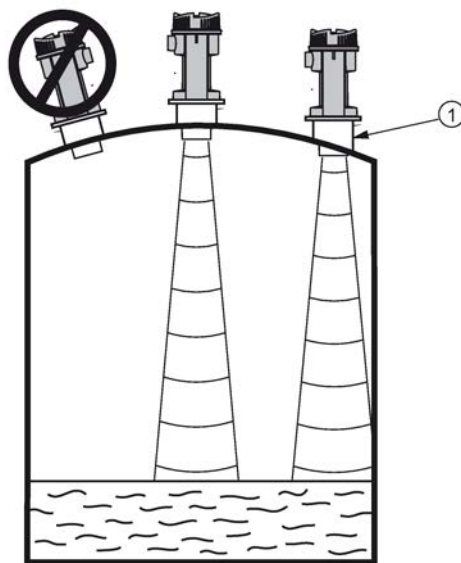

- ① Sanitary ferrule
- ② Pipe
- ③ Rungs

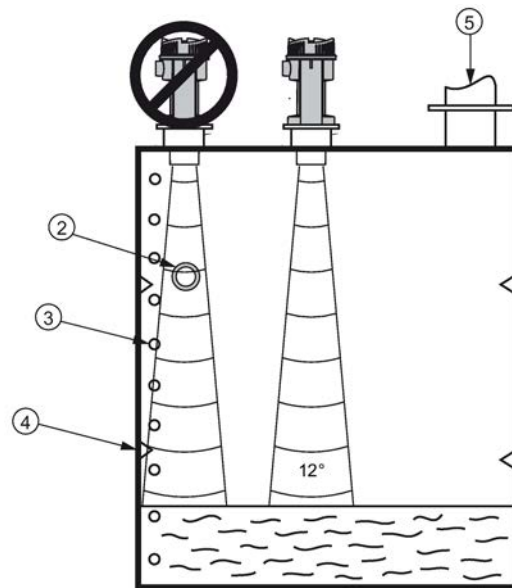

- ④ Seams
- ⑤ Fill

Note

Mount the SITRANS LU150 so that the face of the sensor is at least 25 cm above the highest anticipated level.

3.3 Threaded

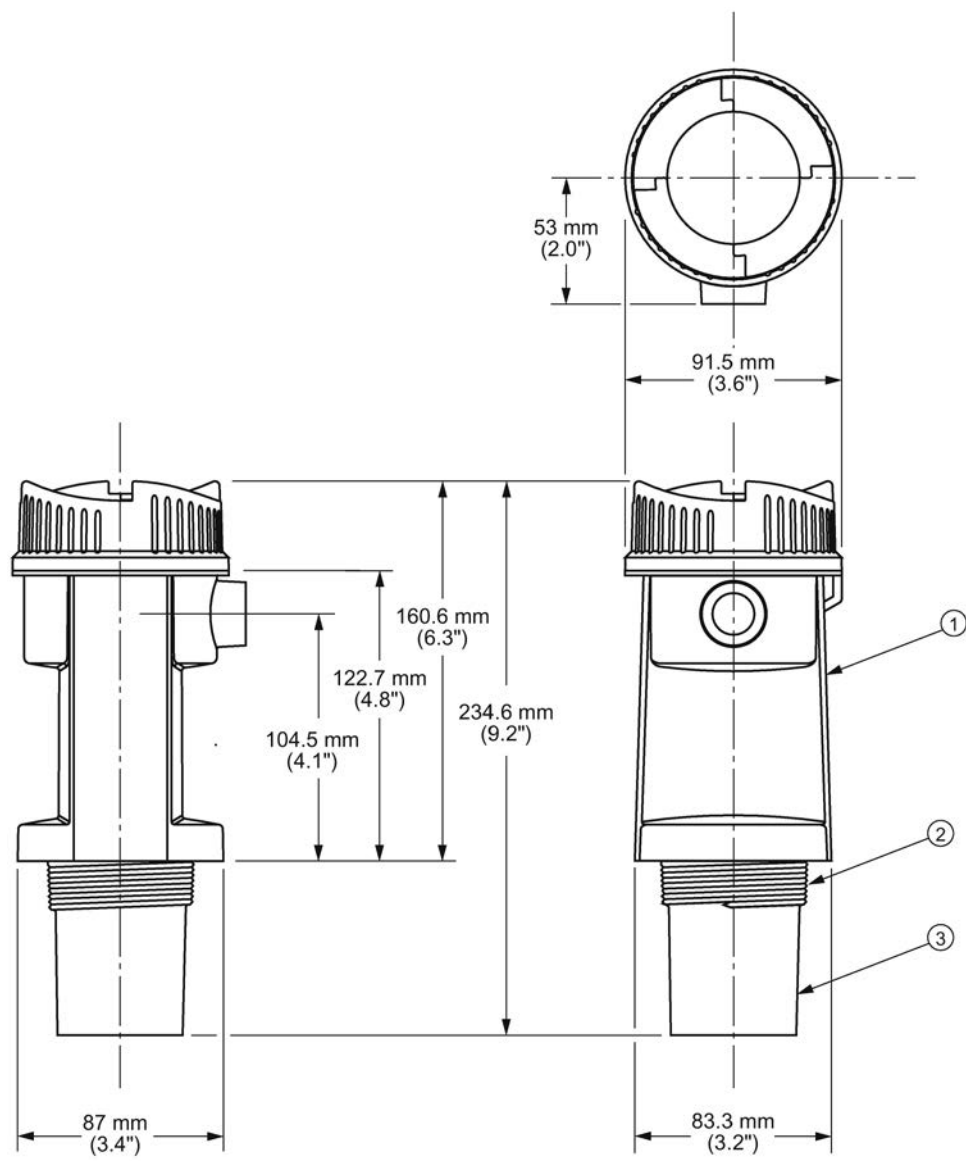

- ① Electronics
- ② Mounting thread
- ③ Sensor

The SITRANS LU150 is available in three thread types:

1. 2" NPT ((Taper), ANSI/ASME B1.20.1)
2. R 2" ((BSPT), EN 10226)
3. G 2" ((BSPP), EN ISO 228-1)

Note

Before inserting the SITRANS LU150 into its mounting hole, ensure that the threads are of the same type to avoid damaging the device.

3.4 Flange adapter (optional)

The SITRANS LU150 can be fitted with the optional 75 mm (3") flange adapter for mating to 3" ANSI, DIN 65PN10 and JIS 10K3B flanges.

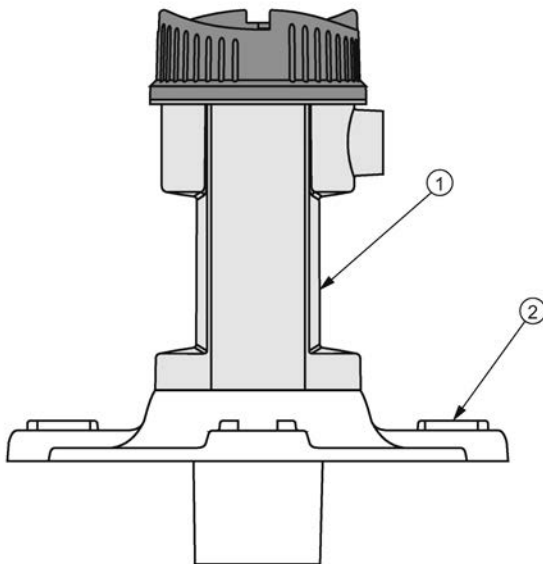
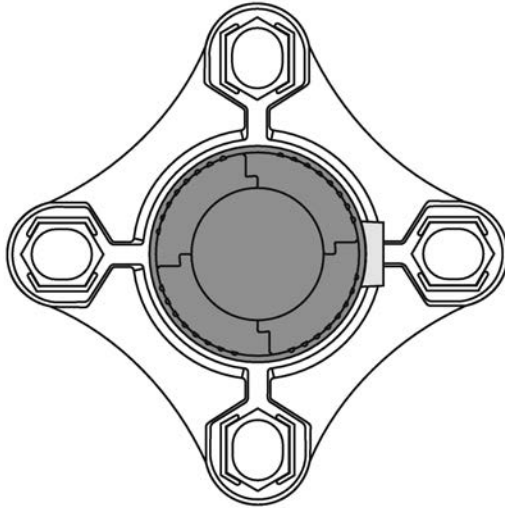

- ① SITRANS LU150
- ② Optional flange adapter (2" NPT - 7ML1830-1BT, 2" BSPT - 7ML1830-1BU)

3.5 4" Sanitary

Note

- The sanitary version is suitable for chemical clean-in-place applications to 60 °C (140 °F) only. Ensure your cleaning chemicals are compatible with PVDF.

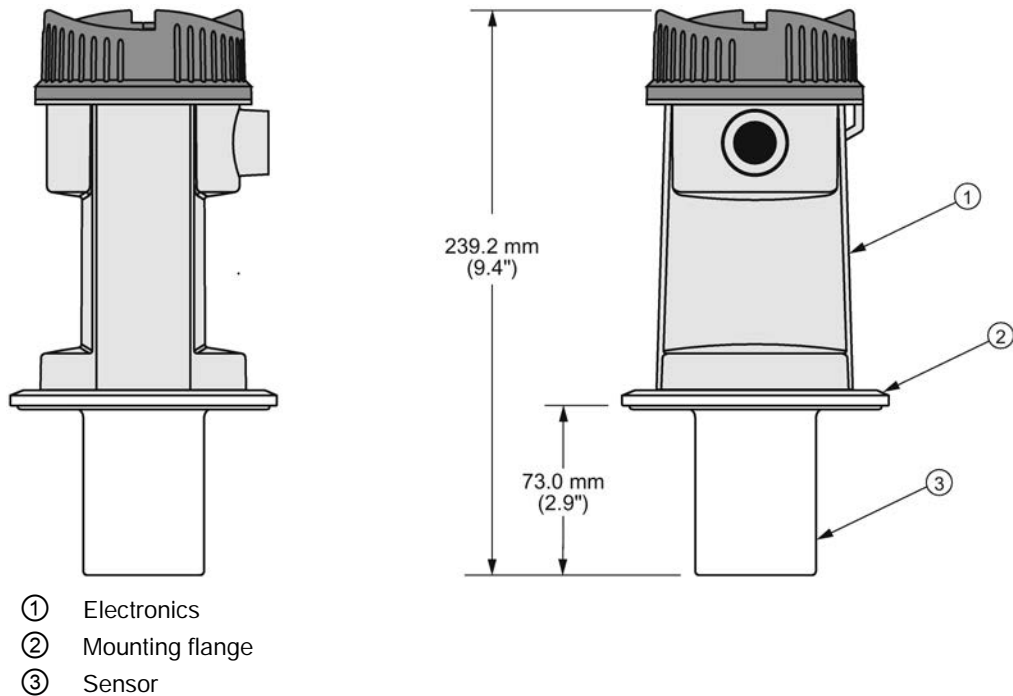

Mounting the sanitary version

1. Mount the SITRANS LU150 onto the top of the tank's sanitary ferrule.
2. Secure mating by surrounding the joint with the clamp.
3. Tighten adjusting wing nut.

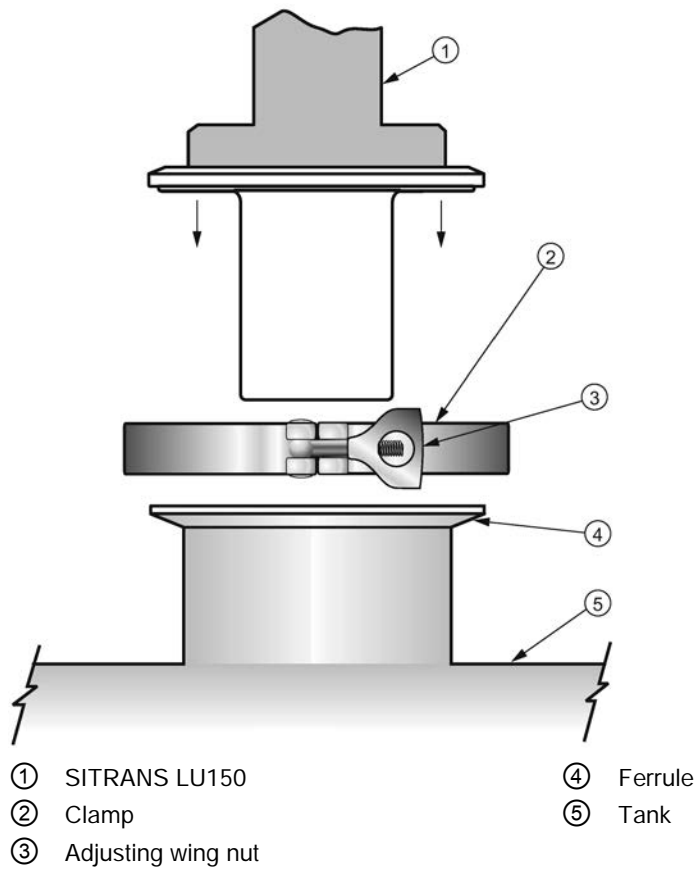

4" Sanitary ferrule

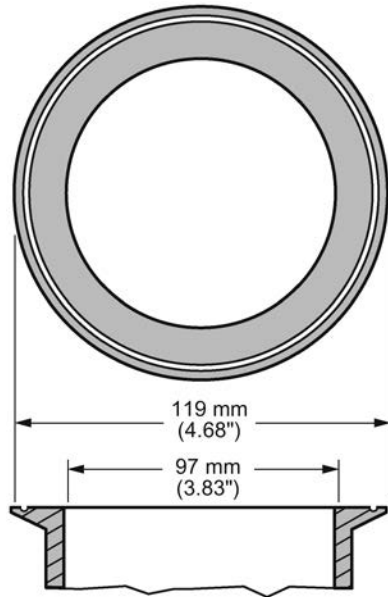

Note

The inside of sanitary ferrule must be smooth, and free of burrs, seams or ridges.

3.6 LU150 with FMS200 mounting bracket

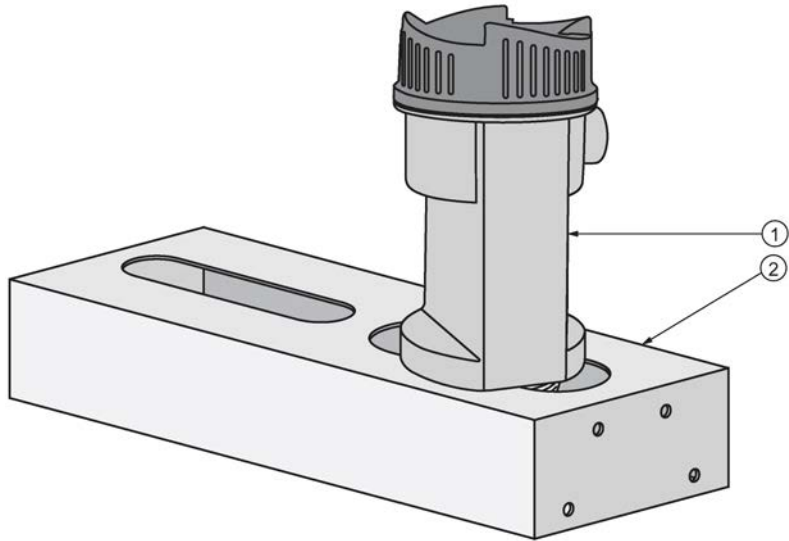

- ① LU150
- ② FMS200 mounting bracket (7ML1830-1BK) with 7ML1830-1DT (Locknut, 2" NPT) or 7ML1830-1DQ (Locknut, 2" BSPT).

Connecting

4.1 Cable entry

1. Loosen lid and remove it.
2. Install cable gland or conduit.
3. Insert wires through gland or conduit and up through cable guide.
4. Connect wiring.
5. Replace lid and tighten it.

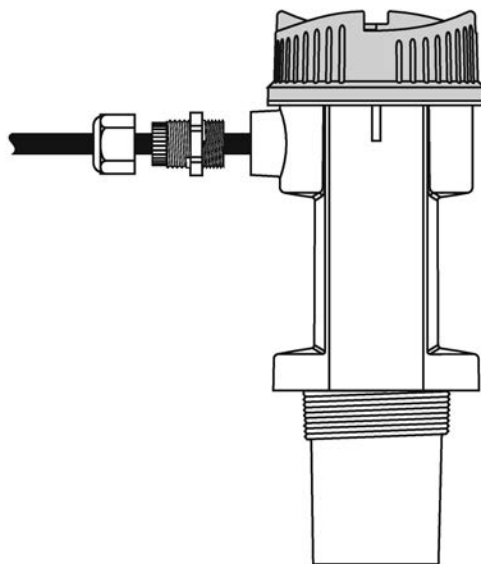
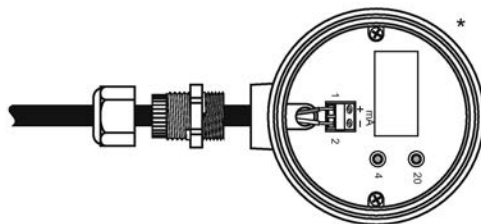

* Lid removed for clarity

Note

- To maintain IP and NEMA ratings, tighten the lid between 4 to 4.5 Nm.
 - Ensure the cable gland is screwed in to the enclosure tightly and the cable is within the specified clamping range (6.5 to 12 mm).
 - User supplied cable glands must meet IP68/NEMA 6 ratings and be installed according to the manufacturer's instructions.
-

4.2 System diagram



- ① SITRANS LU150
- ② Loop instrumentation

4.3 Wiring connection

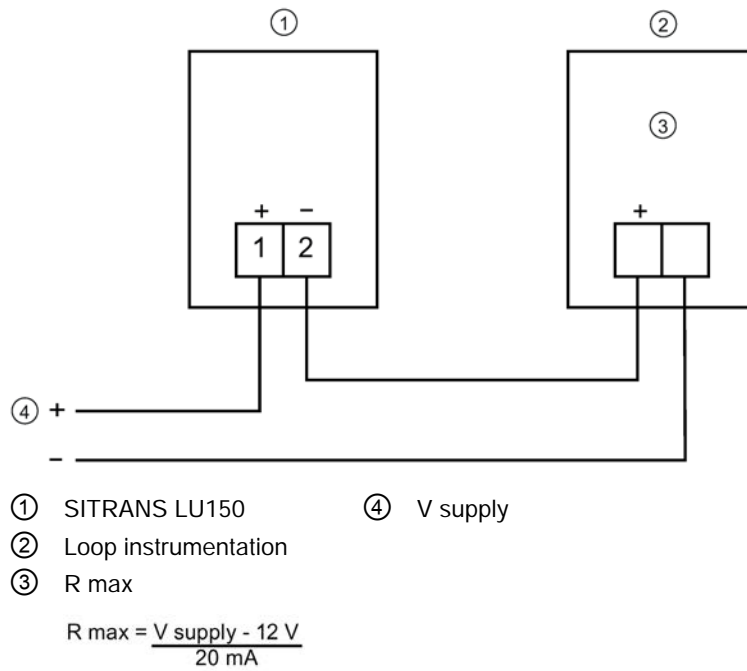

Note

Power supply is reverse polarity protected.

Commissioning

5.1 Start up

1. With the SITRANS LU150 correctly installed (or aimed at a wall 0.25 to 5 m away), apply power.

The device starts up, displaying the following:

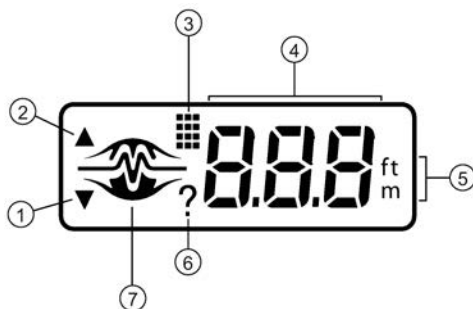

- | | |
|----------------|--------------------|
| ① '4' key | ⑤ Units |
| ② '20' key | ⑥ LOE/fault |
| ③ Program mode | ⑦ Operation status |
| ④ Alphanumeric | |

2. It then defaults to the **Run mode**, which is the measurement reading of the distance from the transducer face to the material level in the units indicated as shown:



5.2 Calibration

The calibration of the mA output may be done such that its span will be either proportional or inversely proportional to the material level.

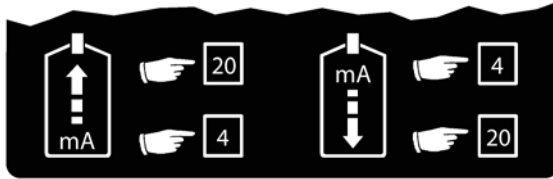

Note

The 4 and 20 mA levels may be calibrated in any order.

Proportional span	Inversely proportional span
high level = 20 mA	high level = 4 mA
low level = 4 mA	low level = 20 mA

5.3 Calibration: reference method

1. Adjust the material level (or target) to the desired distance from the sensor face.
2. Press the "4" or "20" key (as appropriate) to view the stored distance associated with that mA output value.
3. Press the key a second time to set the new distance reference.
4. After viewing or calibrating, the unit operation automatically reverts to the Run mode (6 sec). The calibration value is referenced from the face of SITRANS LU150 sensor, in the units displayed.

5.4 4 mA calibration

Press "4"



Press "4" again

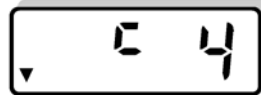

4 mA calibration

calibration invalid if



new 4 mA calibration



retry

5.5 20 mA calibration

Press "20"



Press "20" again

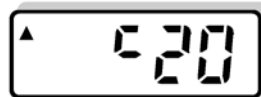

20 mA calibration

calibration invalid if



new 20 mA calibration



retry

Note

Calibration bypasses the measurement response rate.

5.6 Operation status

The graphic portion of the display gives the user a visual indication of the SITRANS LU150 operating status. During commissioning, viewing the graphic can assist the user in properly locating and installing the unit to achieve optimum performance.

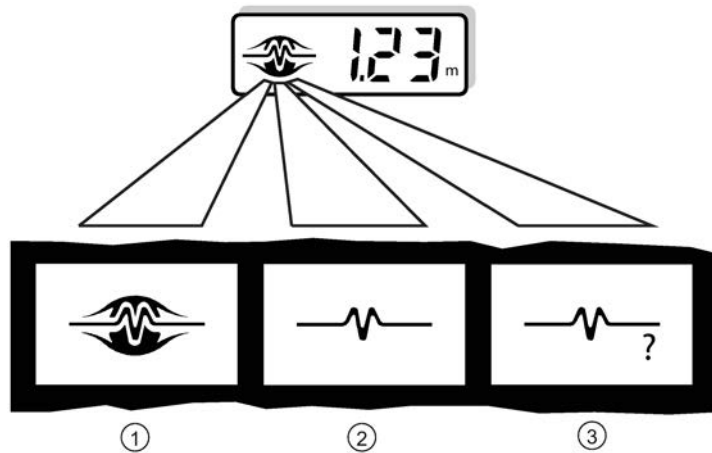

- ① GOOD
- ② WAITING
- ③ LOE / FAULT







The graphic will change from full to partial to indicate operation status. After the 'Waiting' period, the '?' icon will appear for an 'LOE / FAULT' indication. When a valid echo is again received, a 'Good' indication will resume. Refer to Troubleshooting (Page 33).

Operating

6.1 Adjustments

There are several operating adjustments that can be made to the SITRANS LU150.

To access the operating adjustments, simultaneously press the "4" and "20" keys until the desired adjustment is obtained. A viewing sequence of the stored value is automatically initiated. During this time the value can be changed by pressing either the "4" or "20" key. After viewing or changing, operation automatically reverts to the Run mode (6 secs).

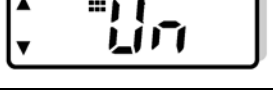
Adjustment	Display
4 mA calibration (Page 26), scrolling	
20 mA calibration (Page 27), scrolling	
Blanking (Page 27)	
Speed of response (Page 29)	
Fail-safe (Page 30)	
Fail-safe timer (Page 31)	
Units (Page 32)	

Note

Calibration bypasses the measurement response rate.

6.2 Calibration, scrolling method

The 4 and 20 mA calibration values can be selected where reference levels, either from the material in the vessel or from a target, cannot be provided. This method can also be used to trim the output levels obtained by the Calibration: reference method (Page 22)

To change the stored calibration value, obtain the 'c 4' or 'c 20' display. The calibration value may be increased by pressing the "20" key or decreased by pressing the "4" key. When the display has scrolled to the desired value, stop pressing the key. The display automatically reverts to the Run mode (6 secs).

Note

For faster scrolling, hold the key, and release it when the appropriate value is shown.

6.3 4 mA calibration



4 mA calibration initiated



view stored 4 mA calibration value
(i.e. 4.50 m)



press "20" to increase to new calibration value
(i.e. 4.60 m)



new calibration value

6.4 20 mA calibration



20 mA calibration initiated



view stored 20 mA calibration value
(i.e. 0.50 m)



press "4" to increase to new calibration value
(i.e. 0.45 m)



new calibration value

6.5 Blanking

Blanking is used to ignore the zone in front of the transducer where false echoes are at a level that interfere with the processing of the true echo. It is measured outward from the sensor face. The minimum recommended blanking value is 0.25 m (0.82 ft) but can be increased in order to extend the blanking.

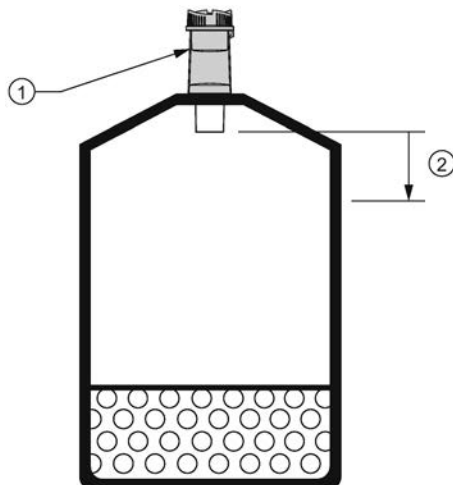

- ① SITRANS LU150
- ② Blanking

6.6 Adjusting the blanking value

To change the stored blanking value, go to the 'bL' display (as described in Adjustments (Page 25)), and proceed as follows:

1. Press the "20" key to increase the blanking value, or the "4" key to decrease it until the correct value is displayed.
2. Release the key. The display automatically returns to the Run mode (6 secs).



3
seconds Indicates that the device is now in blanking mode.



The stored blanking value is shown
(for example 0.25 m)



Press "20" to increase blanking value
(i.e. 0.36 m)



Press "4" to decrease the blanking value
(i.e. 0.35 m)



6
seconds The new blanking value is shown.

6.7 Speed of response

The speed of response adjustment allows the user to collectively set a number of operating parameters.

- measurement response: is the limit to which the SITRANS LU150 will be able to keep up with rates of change. If the unit's measurement cannot keep up with the rate of level change, set the adjustment from '1' to '2'. If it still cannot keep up with the rate of level change, set the adjustment option to '3'. Avoid choosing an option that is too fast for your application.
- agitator discrimination: discriminates between agitator blades in motion, and the material (target) surface.
- filter: discriminates between false echoes from acoustical and electrical noise, and the material (target) surface.
- fail-safe timer: establishes the 'Waiting' period from the time a loss of echo or operating fault condition starts, until the fail-safe default is effected. Adjusting the speed of response will set the fail-safe timer to the default values in the chart. If a different response is required, adjust the 'FSt' option (Fail-safe timer (Page 31)).

SP	measurement response	agitator discrimination	filter	fail-safe timer
1*	1 m/min (3.3 ft/min)	on	on	10 minutes
2	5 m/min (16.4 ft/min)	on	on	3 minutes
3	immediate	off	off	3 minutes
4	0.03 m/min (0.1 ft/min)	on	on	10 minutes

* = factory setting

6.8 Adjusting the speed of response

To change the speed of response, go to the 'SP' display (as described in Adjustments (Page 25)), and proceed as follows:

1. Press the "20" key to scroll forward through the available values (1-2-3), and press the "4" key to scroll backwards.
2. Once you have reached the appropriate value, stop pressing the key. The display automatically returns to the Run mode (6 secs).



3 seconds Indicates that the device is now in speed of response mode.

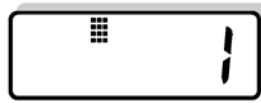

The current option is shown (i.e. 1m/min)



Press "20" for option 2 (i.e. 5 m/min)



6 seconds Option 2 has now been selected.

6.9 Fail-safe

In the event a loss of echo or fault condition exceeds the 'Waiting' period (see Speed of response (Page 29), or Fail-safe timer (Page 31)), the '?' icon appears and one of the following fail-safe defaults is immediately effected.

SP	default	mAp	mAl	reading
1	full	22	4	hold
2	empty	4	22	hold
3*	hold	hold	hold	hold

p = proportional span

i = inversely proportional span

* = factory setting

6.10 Adjusting the fail-safe setting

To change the fail-safe setting, go to the 'FLS' display (as described in Adjustments (Page 25)), and proceed as follows:

1. Press the "20" key to scroll forward through the available values (1-2-3), and press the "4" key to scroll backwards.
2. Once you have reached the appropriate value, stop pressing the key. The display automatically returns to the Run mode (6 secs).

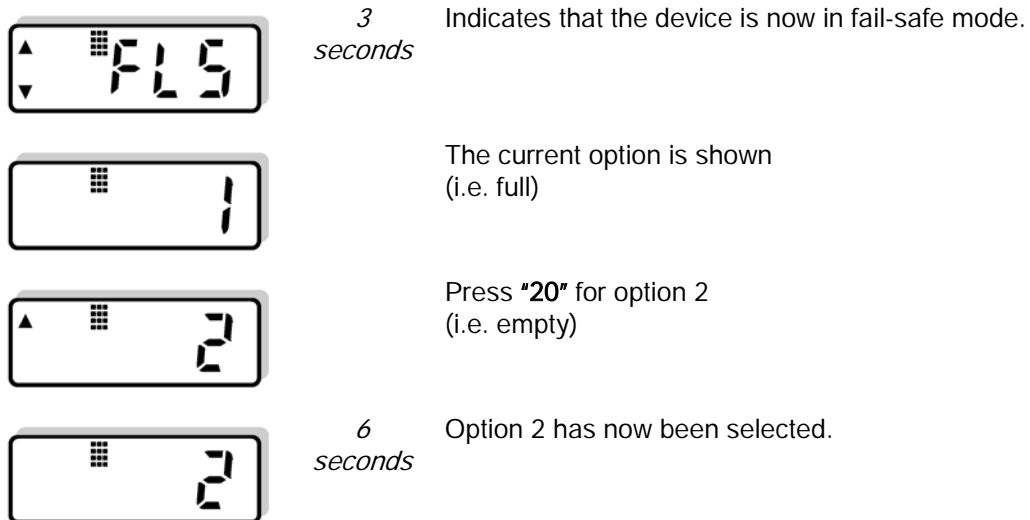

6.11 Fail-safe timer

The fail-safe timer allows the user to vary the 'waiting' period from the time a loss of echo or operating fault condition begins, until the fail-safe default is effected. The 'waiting' period is adjustable from 1 to 15 minutes, in 1 minute increments.

The fail-safe timer value will default to settings determined by the Speed of response (Page 29). If a different value is desired, the fail-safe timer should be adjusted *after* the speed of response is set.

6.12 Adjusting the fail-safe timer

To change the fail-safe setting, go to the 'FSt' display (as described in Adjustments (Page 25)), and proceed as follows:

1. Press the "20" key to increase the 'waiting' period, and press the "4" key to decrease it.
2. Once you have reached the appropriate value, stop pressing the key. The display automatically returns to the Run mode (6 secs).

6.13 Units

The units of the measurement reading can be selected as follows:

1 = metres, m (factory setting)

2 = feet, ft

The selected units are also applicable to the 'Blanking' adjustment.

6.14 Adjusting the units

To change the units, go to the 'Un' display (as described in Adjustments (Page 25)), and proceed as follows:

1. Press the "20" key to scroll forward through the available options (1-2), and press the "4" key to scroll backwards.
2. Once you have reached the appropriate value, stop pressing the key. The display automatically returns to the Run mode (6 secs).



3 seconds Indicates that the device is now in units mode.



The current option is shown (i.e. m)



Press "20" for option 2 (i.e. ft)



6 seconds Option 2 has now been selected.

Troubleshooting

7.1 Troubleshooting



The echo is not reliable and the LU150 is waiting for a valid echo before updating the measurement.

Probable causes are:

- Material or object in contact with sensor face
- The LU150 is too close to the fill point
- The LU150 is not perpendicular to the liquid surface
- Change in level too fast
- Measurement out of range
- Foam on liquid surface
- High level of vibration in the mounting structure
- Level inside the blanking zone

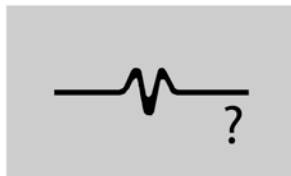

The 'Waiting' period has expired. Investigate the probable causes listed above.

Refer to Speed of response (Page 29) or Fail-safe timer (Page 31) for duration of 'Waiting' periods.

Technical data

Note

Siemens makes every attempt to ensure the accuracy of these specifications but reserves the right to change them at any time.

8.1 Power

12 to 30 V DC (at terminal blocks), 0.1 A surge	
loop current	4 to 20 mA max

8.2 Performance

Range	0.25 to 5 m (0.8 to 16.4 ft) (liquids only)	
Beam angle	12° at -3 dB boundary	
Temperature compensation	built-in to compensate over the operating range	

8.3 Interface

Display	<ul style="list-style-type: none"> • liquid crystal • three 9 mm (0.35") digits for reading of distance between sensor face and material • multi-segment graphic for commissioning and troubleshooting
Programming	2 tactile buttons
Memory	non-volatile EEPROM, no battery required

8.4 Outputs

mA output		
	Range	4 to 20 mA
	Span	proportional or inversely proportional
	Accuracy	0.25% of full scale at reference conditions
	Resolution	3 mm (0.125")
	Loading	600 ohms max loop load at 24 V DC supply
	Cable	twisted pair, AWG 28 to 16 (0.34 to 1.5 mm) or equivalent

8.5 Construction

Combined sensor and electronics package		
Sensor housing	material	PVDF
	mounting	threaded <ul style="list-style-type: none"> • 2" NPT ((Taper), ANSI/ASME B1.20.1) • R 2" ((BSPT), EN 10226) • G 2" ((BSPP), EN ISO 228-1) • 4" Sanitary
	optional flange adapter	<ul style="list-style-type: none"> • 2" NPT - 7ML1830-1BT • 2" BSPT - 7ML1830-1BU
Enclosure material	PBT	
Connection	<ul style="list-style-type: none"> • 1 x M20 or 1/2" NPT conduit entry • 2 screw terminal block for 2.5 mm² • (14 ga) solid wire / 1.5 mm² (16 ga) stranded wire max 	
Enclosure rating	Type 6/NEMA 6/IP68 (2 meters for 24 hours)	
Weight	1.3 kg	

8.6 Operating conditions

Location	indoor / outdoor
Ambient temperature	continuous -30 to +60 °C (-22 to +140 °F) -20 °C (-5 °F) if metal mounting
Relative humidity	suitable for outdoor (Type 6/NEMA 6/IP68 (2 meters for 24 hours))
Installation category	I
Pollution degree	4

8.7 Approvals

Approvals	CE, cCSAus
-----------	------------

Appendix

A

A.1 Measurement interval

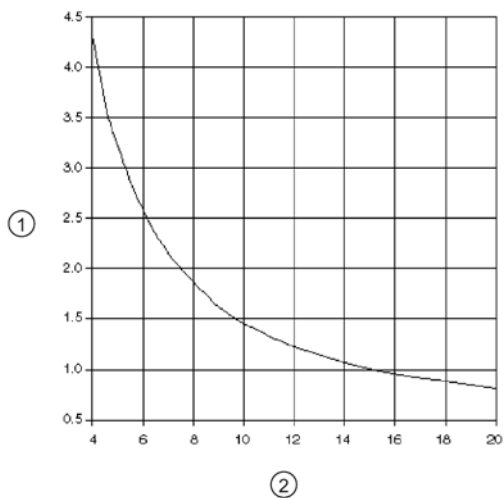

- ① Interval (in seconds)
- ② mA loop current

For more information

www.siemens.com/level

www.siemens.com/weighing

Siemens Canada Limited
1954 Technology Drive
P.O. Box 4225
Peterborough, ON
Canada K9J 7B1

Subject to change without prior notice
A5E34590123 Rev. AB
© Siemens AG 2016



Printed in Canada

www.siemens.com/processautomation