

BEZBEDNOŠNA TEHNOLOGIJA  
ZA ZAŠTITU ŽIVOTNE SREDINE

SAFETY AND  
ENVIRONMENTAL  
TECHNOLOGY

  
FÜLLSTANDSGERÄTE

13-01-02E

## **Kompaktni ultrasonični senzor nivoa US-100**

Ultrasonični senzor nivoa transmituje ultrasonične impulse koji se brzo smenjuju i reflektuje ih površina supstance. Vremenski interval od transmisije do recepcije reflektovanog signala se meri vrlo tačno. Prolazno vreme impulsa je direktno proporcionalno razdaljini između senzora nivoa i površine supstance. Mikroprocesor procenjuje signal odjeka i meri nivo ispunjavanja. Promene ultrasonične brzine izazvane promenama temperature se kompenzuju. Integrisan softver omogućava da se koristan odjek filtrira i procenjuje, čak i u nepovoljnim uslovima. Na taj način je moguće napraviti tačne i pouzdane procene u blizini do tačke neposredno pre senzora.

Elektronski uređaji se nalaze u vodootpornom plastičnom kucištu. Kucište je otporno na korozivne materijale i može da izdrži visoke temperaturne fluktuacije

- Merenje bez kontakta
- Lako za održavanje i otporno na trošenje i habanje (nema mehanickih delova)
- Temperatura je kompenzovana
- Laka kalibracija

## **Detalji o sistemu**

Sistem za merenje sastoji se iz : ultrasoničnog senzora nivoa i displeja AD-310 ili AD-313 (vidite sekciju 13)

## **Compact Ultrasonic Level Sensor US-100**

The ultrasonic level sensor transmits ultrasonic pulses in quick succession which are reflected from the medium's surface. The time interval from transmission to reception of the reflected signal is measured exactly. The impulse running time is directly proportional to the distance between the level sensor and the medium surface. A microprocessor evaluates the echo signals and measures the filling level. Changes in the ultrasonic speed caused by changing temperatures are compensated. The integrated software enables the useful echo to be filtered out and evaluated, even under unfavourable conditions. Thus it is possible to make reliable measurements in the vicinity, up to a point just before the sensor.

The electronics are accommodated in a waterproof plastic casing. The casing is resistant to corrosive materials and can tolerate high temperature fluctuations.

- Contactless measurement
- Maintenance-free and wear-resistant (no mechanical parts)
- Temperature-compensated
- Easy calibration

## **System Details**

The measuring system consists of the ultrasonic level sensor and a display AD-310 or AD-313 (see section 13).



US-100

ULTRASCHALL • ULTRASONIC



## Tehnicki podaci

Sistem zaštite	IP 65
EN 60529	
Napajanje voltaže	18...30 V DC
Ulazna struja	Max. 5W (200mA na 24 VDC)
Merni obim	0,25...5,0m
opcija	0,25...8,0m
Merni raspon	10...4750mm
Opција	10...7750mm
materijali za merenje	Sve tecnosti
Tacnost u merenju	±0,25% mernog obima u vazduhu
Temp. kompenzacije	Integrirana u senzoru
Izlaz	4...20 mA / 750Ω na 24 V DC
Displej	LDC sa tri cifre sa grafickim displejem
Operativna temp.	-20...+60°C
Temp. otpor	Strana supstance max. 110°C za maksimum 30 minuta
Signal greške	Samo sa verzijom sa 3 provodnika uspostavljanje veze sa odlaganjem od 10 minuta u slučajevima gubitka odjeka, greske ili prekida voltaže
Radni pritisak	Max. 2 bar
Veza procesa	G 2" navoj
Opција	2" NPT; jezicak od PVC DN 65 PN 10 do DN 200 PN 10
Težina	1,7kg
Ulaz za kabl	22mm za M20x1.5 sa obe strane

## Programiranje

Dva dugmeta su dovoljna za programiranje u dijalogu na ploči displeja. Ne može da bude jednostavnije. Mali broj ulaza kroz ova dva dugmeta se odvija kroz dijalog preko displeja i vrlo je lako to naučiti, čak i bez posebnih instrukcija. Ako je rezervoar prazan, ili ako je nivo u tacki u kojoj zahteva 20mA, dva puta pritisnite dugme 20. Uredjaj je sada kalibriran. Dalje mogućnosti za podešavanja su ako se udje u nulti i kranji nivo direktno.

## Odluke performanse

**Merni obim:** 0.25 do 5 m (opcija 8 m)  
**Supstance:** sve tecnosti  
**Izlaz:** 4...20mA, nivo ispunjavanja ili udaljenost, bez derivacija  
**Programiranje:** 4...20mA, kvalitet odjeka na displeju i udaljenost u metrima.  
**Parametri skladišta:** E<sup>2</sup>PROM  
**Alarmni kontakt greške:** uz verziju sa 3 provodnika, prekid voltaže i gubitak odjeka  
**Vlaga:** podesivo u metrima u minuti (1m, 3m i odloženo)

## Kljuc tipa

Osnovne oznake

Tip  
 1= merni obim 0.25...5m, 18...30 VDC, 3 provodnika  
 2= merni obim 0.25...5m, 12...28 VDC, 2 provodnika  
 3= merni obim 0.25...8m, 18...30 VDC, 3 provodnika  
 4= Ex oblast

US-100□

## Technical Data

Sys. of protection	EN 60529 IP 65
Voltage supply	18...30 VDC
Power consumption	max. 5W (200 mA at 24 V DC)
Measuring range	0,25...5,0 m
Option	0,25...8,0 m
Measuring span	10...4750 mm
Option	10...7750 mm
Measurable materials	all liquids
Measuring accuracy	± 0,25 % of measuring range in air
Temperature compensation	integrated in sensor
Output	4...20 mA / 750 Ω at 24 V DC
Display	3-digit LCD with graphic display
Operating temperature	-20...+60 °C
Temperature resistance	medium side max. 110°C for maximum 30 minutes
Fault signal	only with 3-conductor version Contact making with 10 minutes delay in case of echo loss, fault or voltage breakdown
Working pressure	max. 2 bar
Process connection	G 2" thread
Option	2" NPT; flange of PVC DN 65 PN 10 up to DN 200 PN 10
Weight	1,7 kg
Cable inlet	22 mm for M 20 x 1.5 both sides

## Programming

Two push buttons are sufficient for programming in dialogue with the display panel. It couldn't be simpler. The small number of inputs via these two push buttons take place in dialogue with the display and are very easy to learn, even without instructions. If the tank is empty, or if the level is at a point at which it requires 20 mA, operate push button 20 twice. The device is now calibrated. A further possibility of adjusting is to enter the zero and final value directly.

## Performance Features

**Measuring range:** 0.25 to 5 m (option 8 m)  
**Media:** All liquids  
**Output:** 4...20 mA, filling level or distance, drift-free  
**Programming:** 4...20 mA, display of echo quality and distance in metres  
**Parameter storage:** E<sup>2</sup>PROM  
**Fault alarm contact:** With 3-conductor version, voltage breakdown and echo loss  
**Damping:** Adjustable in metres per minute (1 m, 3 m and delayed)

## Type Key

Basic designation

Type  
 1 = measuring range 0.25...5 m, 18...30 VDC, 3-conductor  
 2 = measuring range 0.25...5 m, 12...28 VDC, 2-conductor  
 3 = measuring range 0.25...8 m, 18...30 VDC, 3-conductor  
 4 = Ex-area

US-100□

## Dimenzioni crtez Dimensional Drawing

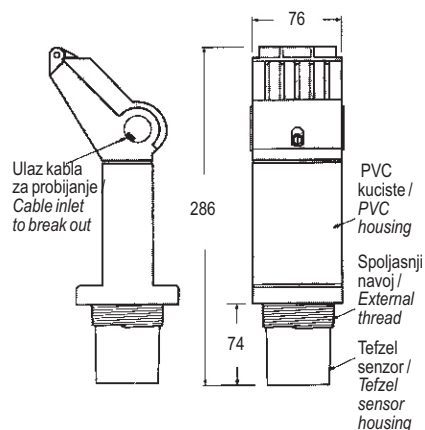

Dimenzije u mm / Dimensioning in mm

## Lokacija instalacije Installation Location

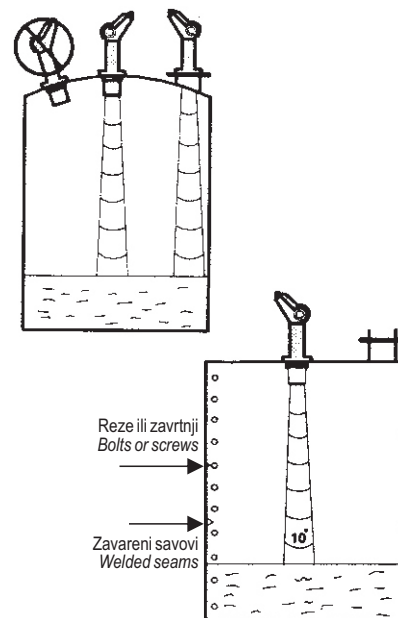

Kompaktni ultrasonični senzor nivoa mora biti instaliran tako da zvuk može da dopre do površine materijala neometan i vertikalno u odnosu na površinu. Veoma je važno da je obezbeđen slobodan prostor od 250mm od donje ivice senzora i očekivanog maksimalnog ispunjavanja.

Određena razdaljina mora se održati u odnosu na instalirane komponente koje mogu da ometaju proces, kao što su merdevine, cevi, ukršteni podupiraci, ili debelo zavareni savovi.

The compact ultrasonic level sensor must be installed in such a way that sound can reach the material surface unhindered and perpendicular to it. It is important that a free space of 250 mm is guaranteed between the lower edge of the sensor and the maximum anticipated filling level.

A certain distance must be maintained from disturbing installed components, such as ladders, pipes, cross-struts or thick weld seams.

Moguće izmene bez prethodne najave.

Subject to change without prior notice, errors excepted.